

COLUMBUS
Children's
THEATRE

Study
Guide
for...

THE ELEVATOR FAMILY



By Douglas Evans
Based on his book The Elevator Family

THE COLUMBUS FOUNDATION
The Center for Charitable Giving™

 Greater Columbus Arts Council

Ohio Arts Council

Theatre Etiquette



Part of CCT's mission is to nurture future audiences. We believe that the arts are a critical aspect of education. We thank you for valuing the experience of live theatre and for allowing Columbus Children's Theatre to share the theatrical arts with you and your family.

Here are some general rules of etiquette that if followed will help every one enjoy the performance.

1. The most important rule: **DO UNTO OTHERS AS YOU WOULD HAVE THEM DO TO YOU**. Courtesy makes everything run smoothly and the experience that much more enjoyable for everyone.
2. Positive audience sounds are encouraged! Applause and laughter at the appropriate times are appreciated by the actors. Cheering, whistling, and shouting are best saved for sporting events.
3. During the performance, listen and watch closely. Talking during the performance will disturb others around you, and you may miss the best part.
4. Have fun and enjoy the show!

Setting the Stage

Did you know, the theatre stage used to be on an incline and the audience sat on a flat surface? When an actor walked to the back of the stage toward the set they were really walking up a *very* steep incline. Now the audience is usually on the incline and the actors are on a flat surface.

Upstage Right	Upstage Center	Upstage Left
Stage Right	Center Stage	Stage Left
Downstage Right	Downstage Center	Downstage Left

Did you know, the theatre stage used to be on an incline and the audience sat on a flat surface? When an actor walked to the back of the stage toward the set they were really walking up a *very* steep incline. Now the audience is usually on the incline and the actors are on a flat surface. The above chart demonstrates the areas of the acting space and the places an actor may need to stand. You will also notice that the right and left are not our reading right and left. That is because this is from the actors view of the audience. All directions are given for the actor in mind, trust me, as a director it can sometimes get confusing. Tape out an area on the playground or classroom and see how well you know your stage directions. Watch the actors during the show, can you remember some of the areas they used?

About the Author



Douglas Evans



Douglas Evans lives in California, but he grew up in Minnesota and Ohio. He has also taught in many different places for twenty years, including Oregon, California, Helsinki and London! He loves to travel and has visited more than 100 countries! Other than writing books, he likes to play music on the guitar and piano. He has written more than 400 musical songs and compositions!

Evans has said that when he met the famous author Roald Dahl (he wrote books like Matilda and Charlie and the Chocolate Factory), he was inspired to write children's books. He most enjoys writing books about students and teachers, which is in fact what many of his books are about. He has said that his favorite book that he has written is Apple Island, which is about teachers.

Find out more at www.wtmelon.com/!

Books by Douglas Evans:

Classroom at the End of the Hall

So What Do You Do?

Apple Island, or, The Truth About Teachers

The Elevator Family

Math Rashes and Other Classroom Tales

MVP: Magellan Voyage Project

Mouth Moths, More Classroom Tales



An illustration from one of Douglas Evans' books

COLOR YOUR OWN SUITCASE!



If you were going on vacation, what would your suitcase look like?
What would be in your suitcase?

wOr D sEaRcH

The names of some of the characters are hidden in this word search!
Can you find them? The names can be hidden in any direction,
even backwards or diagonally!

C A W D G G M Q G Y I H U B D
O H B O F E N M K H H D V B Y
K C Q D L L Y C S X Y A N F M
J A Q O K S D E R A N O B N J
M T K I P Z N L V K T Y J D S
W A J V V E V I U G F Z N O B
K N V K O G Z E W I Y N M U R
L W O F S F A N Z J C O D M H
Y E N T I H W V L V Z Z E O J
X S D H W M H I I R L R Y R C
W I N O N A Z U P N E C Q U A
D H V E J Z K D M T Z J J S T
X Y T I Y X T D L H B L X P H
M J R U O G W A Z F F Q U K Y
B H Y C R J W U G C T H F C G

CATHY
LIZZY
WHITNEY

GAVIN
NATACHA
WINONA

JOE
WALTER
WINSLOW

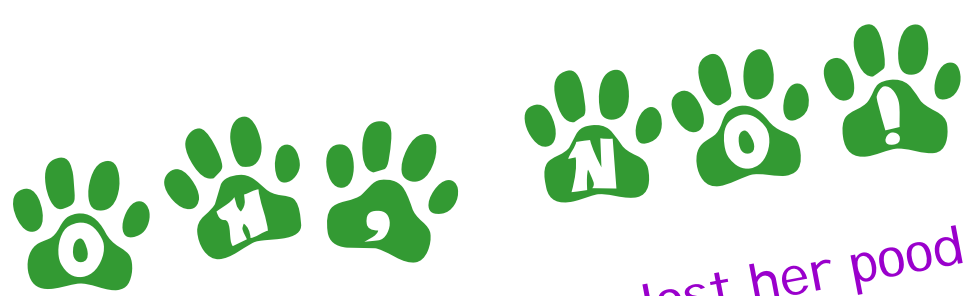

Could you please help me?

Mrs. Goldengate has lost her poodle, Oui-Oui! Can you help her find Oui-Oui?

Start Here!

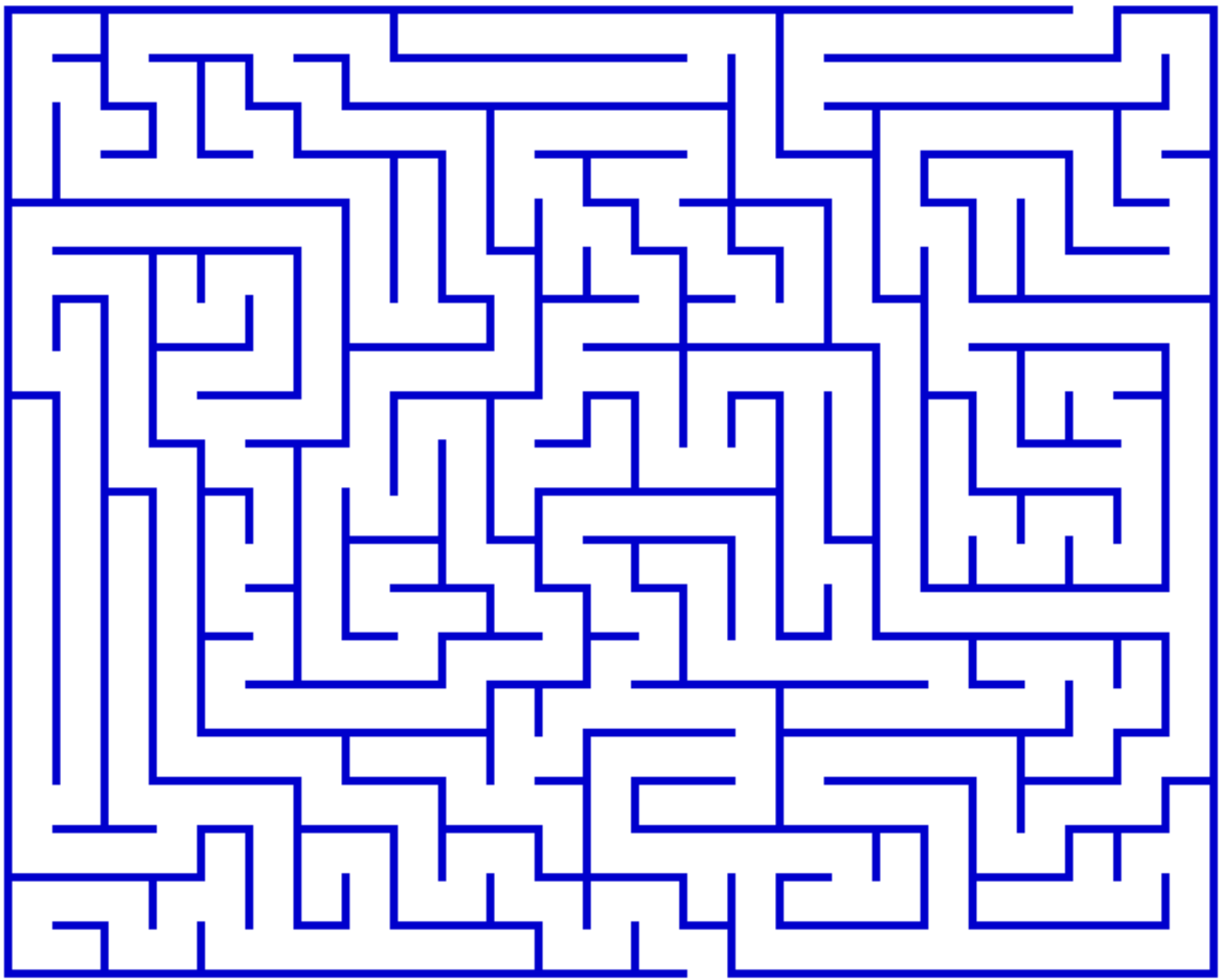

Thanks for your help!

Yay! You found Oui-Oui!

how does an

ELEVATOR

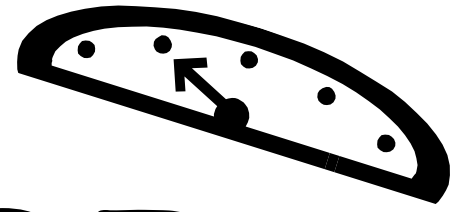

work?

A hydraulic elevator

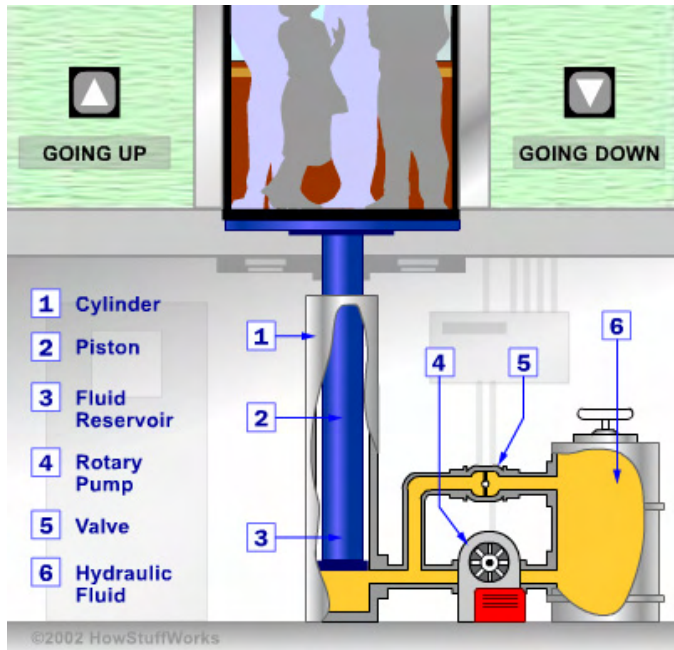

Some elevators today are called *hydraulic* elevators, which means that they need fluid to run! That might sound silly, but it really does make sense. A *hydraulic ram*, which you can see in the diagram to the left, is a *piston* (2) inside a *cylinder* (1) that makes the *elevator car* (where you stand!) move up and down. The cylinder is connected to a *fluid-pumping system* (the fluid is *oil*) which is made up of a *tank* where the oil is, a *pump* (4) make the oil exit the tank, and a *valve* (5) which is the opening from the tank to the cylinder that the oil goes through. The oil is *pressurized* (kept under pressure) so that when the valve is open, the oil

is forced to go into the tank and the elevator goes down. When the valve is closed, the oil goes into the cylinder and forces the piston to go up, making the elevator go up! When the elevator gets to the right floor, the pump shuts off and the oil has to stay where it is so that the elevator stops moving.

The other type of elevator that exists is called a *roped* elevator, seen in the diagram on the right. Instead of being pushed by a piston, the car is controlled by *traction steel ropes* (which are very strong) attached to the car and looped around a *sheave* (3) which is like a big spool of thread and spins when the *control system* (1) gets a signal from someone pushing a button that the elevator should move. The sheave is controlled by an *electric motor* (2). The ropes that make the car go up and down have an attached *counterweight* (4) that balances the elevator car to make it easier for the motor to make the car move. This conserves energy! The heavier the elevator car is, the more energy it takes for it to move. The elevator car and the counterweight travel up and down on separate steel *guide rails* (5) so the elevator doesn't sway from side to side and bump into anything. They also make it a lot easier for the elevator to stop, in case there is an emergency.

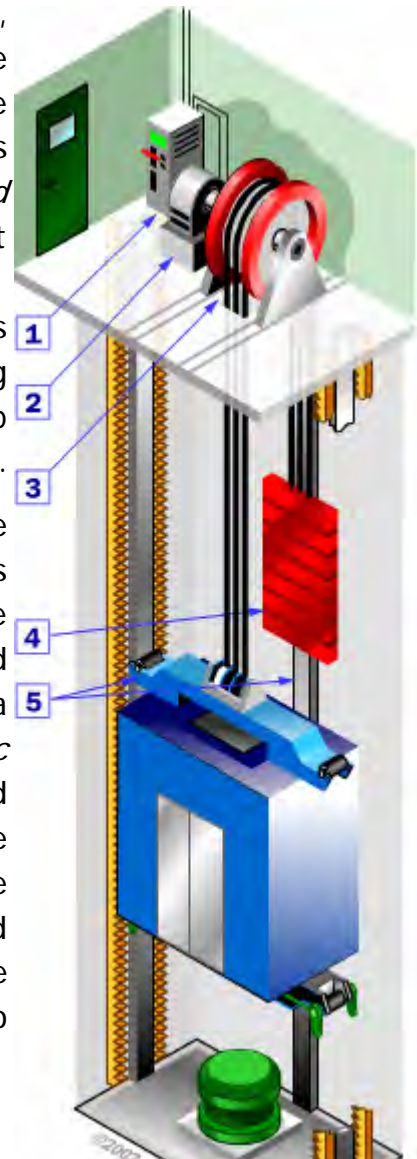

A roped elevator

1 2 3 4 5 6 7 8 9

Your dream vacation!

Imagine that you are going on the vacation of your dreams!

Write down what your dream vacation would be like.

Where would you go? _____

How would you get there? _____

Who would you take with you? _____

What kinds of things would you do there? _____

Draw a picture of your dream vacation spot!

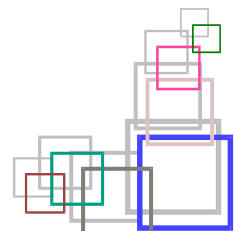
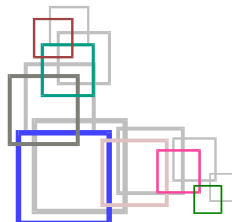
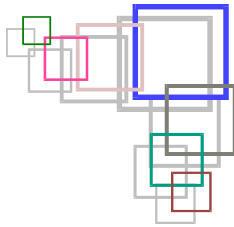
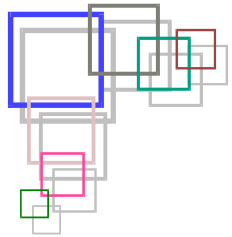

make your own

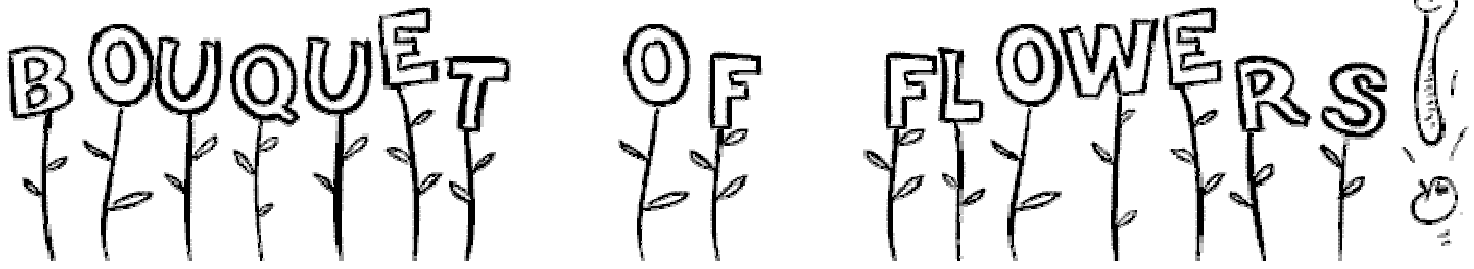

The Wilson's room, Otis, was always full of flowers that Gavin the Bellhop bought from Cindy. You can make your own flowers, and they will last a lot longer than the ones that Gavin bought!

Materials:

- Tissue paper (any color you want!)
- Pipe cleaners (green, or other colors)
- Scissors (use kid-safe ones, and have adult supervision!)

Instructions:

- First, use your scissors to cut the tissue paper into whatever size rectangles you want. 5 inches by 7 inches is a good medium size. You might want to have an adult or older sibling cut the tissue paper for you.
- Stack about 15 of these tissue paper pieces on top of each other. You can stack different colored pieces to make a multi-colored flower!
- Accordion-pleat (see the image in the bottom left corner for an example) the stack of tissue paper, starting with the longer side of the rectangle.
- Wind one end of the pipe cleaner around the middle of the pleated stack.
- Trim the ends of the tissue paper to make the paper look more like flower petals. Trimming the ends into a point or a curve will make very pretty petals. Again, an adult or older sibling can do this for you.
- Make as many flowers as you want! You can put them in a cup or a vase to display in a room, or tie them together with a ribbon or string and give them as a gift!

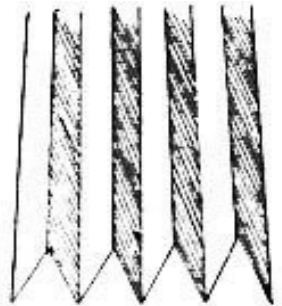

If you liked The Elevator Family...

...you might love these books!

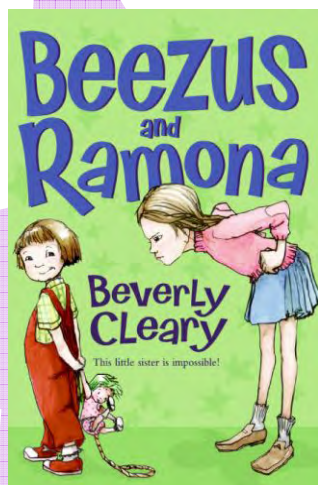

Beezus and Ramona
by Beverly Cleary

This funny and touching story of two sisters who can't seem to get along is a favorite for all ages! How will Beezus put up with her little sister Ramona?

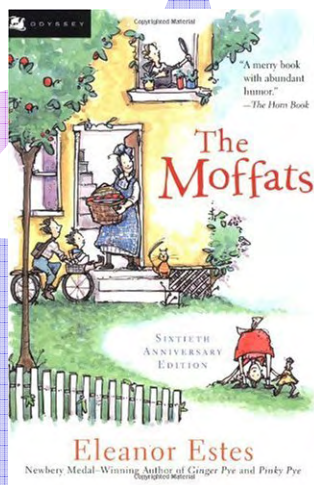

The Moffats
by Eleanor Estes

Follow Mama Moffat and her four children on their wacky adventures in this classic tale that has been making readers laugh for nearly seventy years!

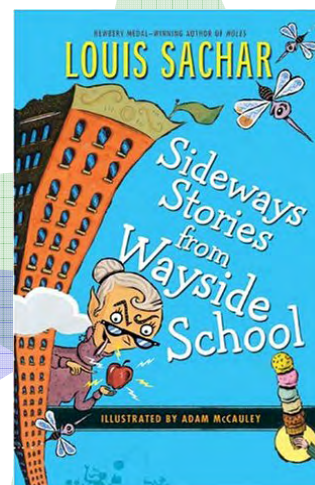

Sideways Stories from Wayside School
by Louis Sachar

Nothing is normal at the topsy-turvy Wayside School! These zany characters and their stories are a riot for everyone!

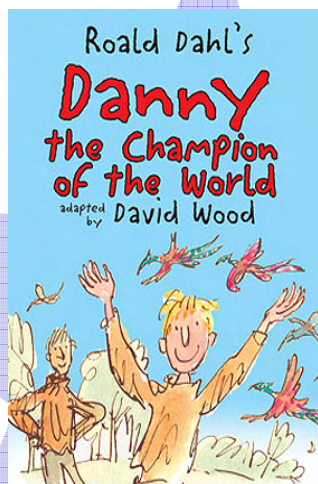

Danny, the Champion of the World by Roald Dahl

A loving but poor father and son are the stars of this book. Their exciting escapades are so fun to read that you won't want to put this book down!

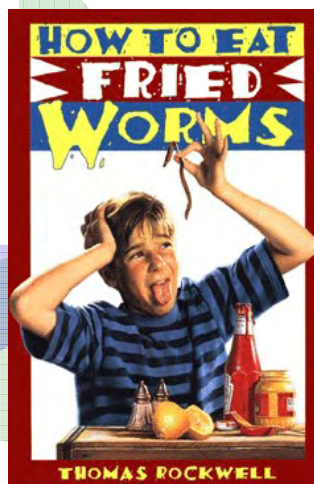

How to Eat Fried Worms
by Thomas Rockwell

This gross but giggly tale of a boy determined to win a bet has entertained kids and adults alike for years! Can Billy eat fifteen worms in fifteen days?

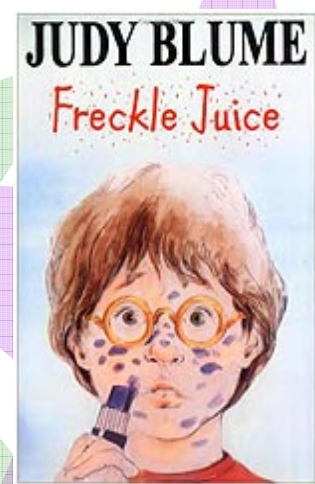

Freckle Juice
by Judy Blume

Andrew wants freckles more than anything. He pays shrewd Sharon fifty cents for a recipe for "freckle juice", and gets himself into some scrapes!

COLUMBUS
Children's
THEATRE
2010-2011 Season



CLICK, CLACK, MOO
 Cows That Type

September 16 - October 3, 2010



The Dinosaur Musical

October 14 - 24, 2010



BABES IN TOYLAND

November 26 - December 19, 2010



Alice in Wonderland

January 6 - 16, 2011



THE ELEVATOR FAMILY

February 3 - 20, 2011



STUART LITTLE

March 10 - 27, 2011



Cinderella

April 14 - 24, 2011



The Three Little Pigs

May 5 - 15, 2011

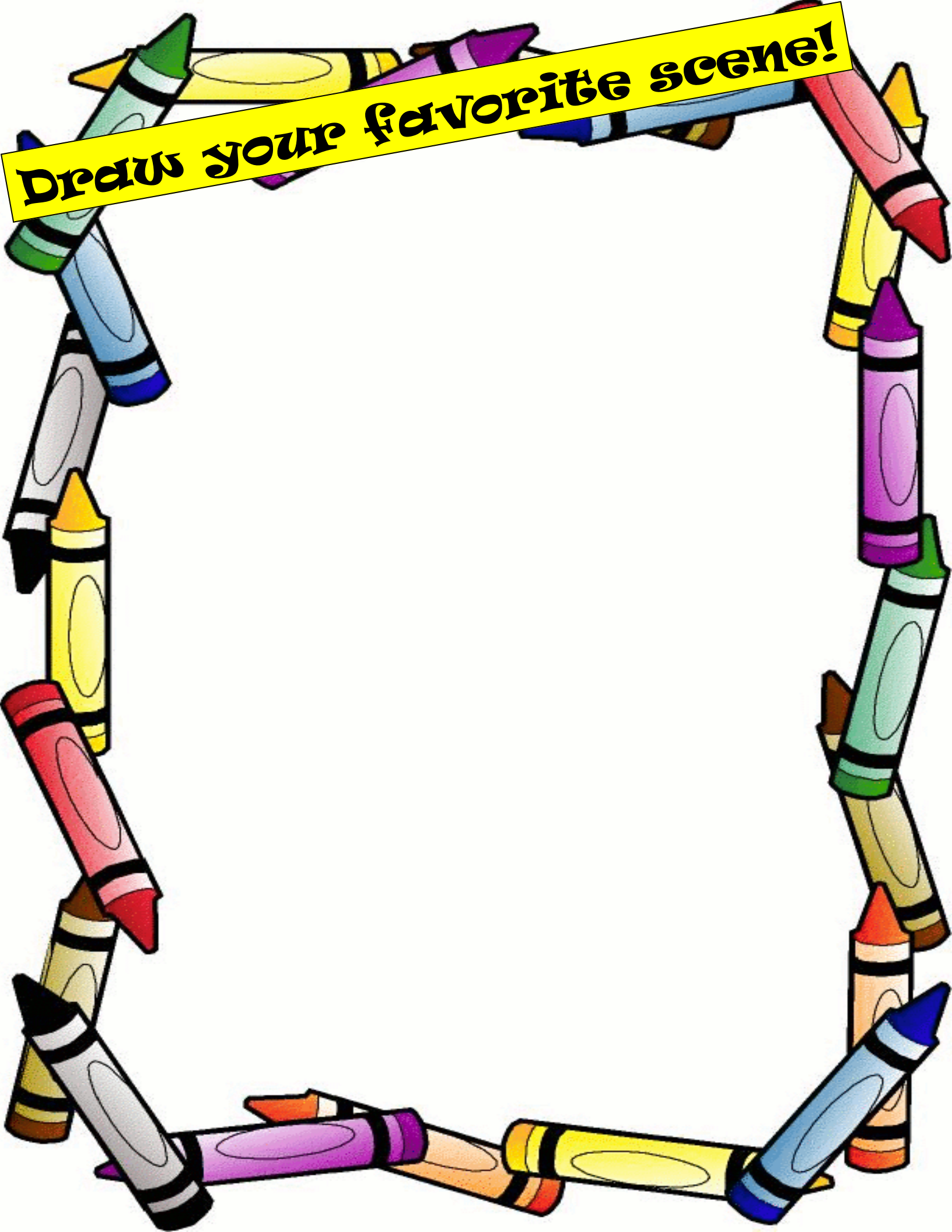

Draw your favorite scene!

